

Strip down process for Epsilon Couplers being sent to Assentech Service Centre

Step 1
Identify Coupler to be stripped for servicing.

Step 2
Record Serial Numbers/Part Numbers and any unique markings.

Step 3
Record site location, confirm reference number to be detailed on test certificates.

Step 4
Dismantle In accordance with OPW Epsilon Manual Version 9 P52-55

Step 5
Dispose of parts numbered 1,12,15,16,17,21,25 and 27 in exploded diagram (attached but also detailed in OPW Epsilon Manual Version 9)

Step 6
Check the Handle Part 8 for any splits, cracks or crazing of the cover. If damage is found remove cover and dispose of. Also check for any obvious damage to the steel body. Once checks have been carried out inform Supervisor so spares can be ordered through Assentech if needed.

Step 7
Check Flange Part 19 for damage paying attention to the locating lugs on the mating face. Also check tapered leading edge for damage.

Any issues contact Assentech Engineers On 01726 844707



Step 8
Clean and decontaminate all stripped parts by understanding and fulfilling your company's chemical decontamination protocol.

Step 12
INITIAL EACH STEP OF THIS PROCEDURE

Step 11
Put all Adaptors/parts to be serviced in shipping box clearly marked with "FAO Assentech Engineers – Epsilons Within"

Step 11
Include packing list with shipment. Detail:-

- Units – model, serial number, ID for certificates and site location
- To be returned by date
- Your name and contact details

Step 10
Refer to drawing to ensure that all parts of the unit are packaged in shipment to Assentech.

Step 9
Place all cleaned and dried parts in a clear plastic bag with MSDS and decontamination cert attached externally.

Disassembly of the Hose/Coupler Half

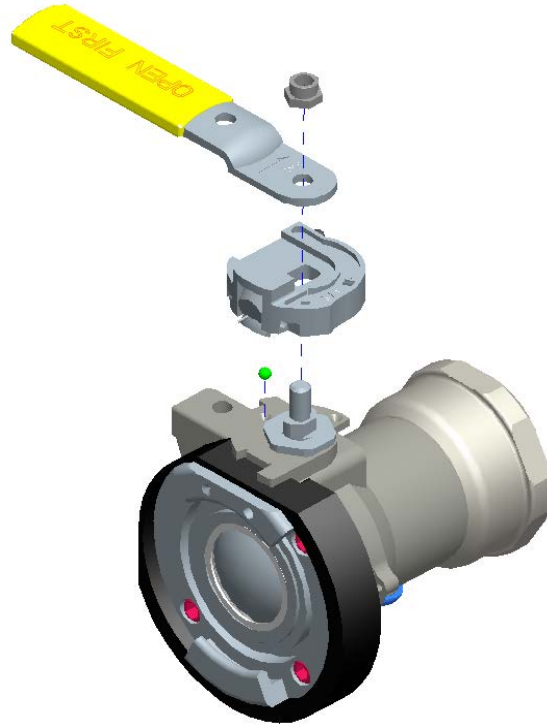

- Loosen handle nut and remove handle, handle hub assembly and detent ball

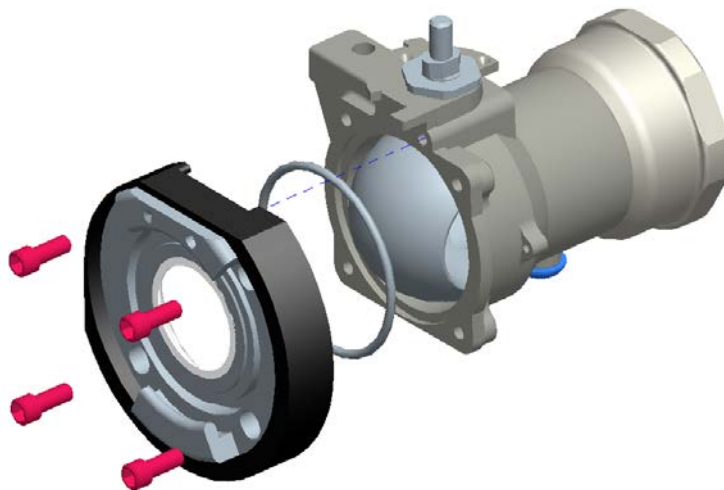

- Loosen flange bolts and remove flange / ball seal assembly and flange seal



- Pop ball seal (16) out of flange, remove flange from rubber bumper

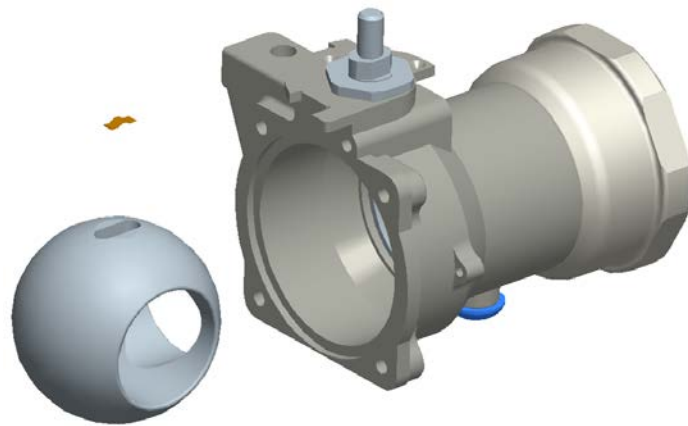

- Rotate ball out of socket, be sure to secure conductivity spring located in blind slot

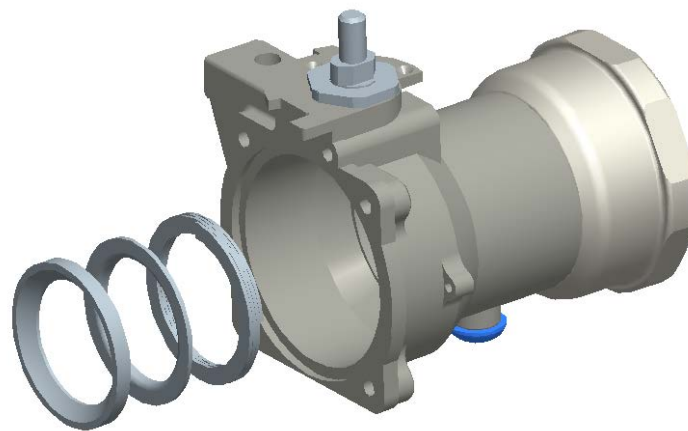

- Pull ball seal along with washer and spring out of body

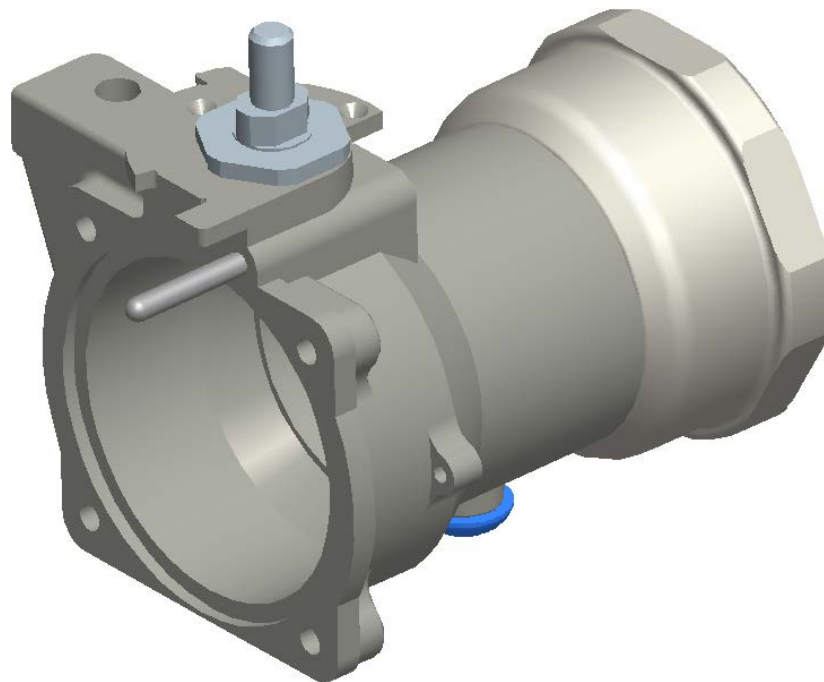

- Rotate stem with wrench, clockwise, until interlock rack falls out

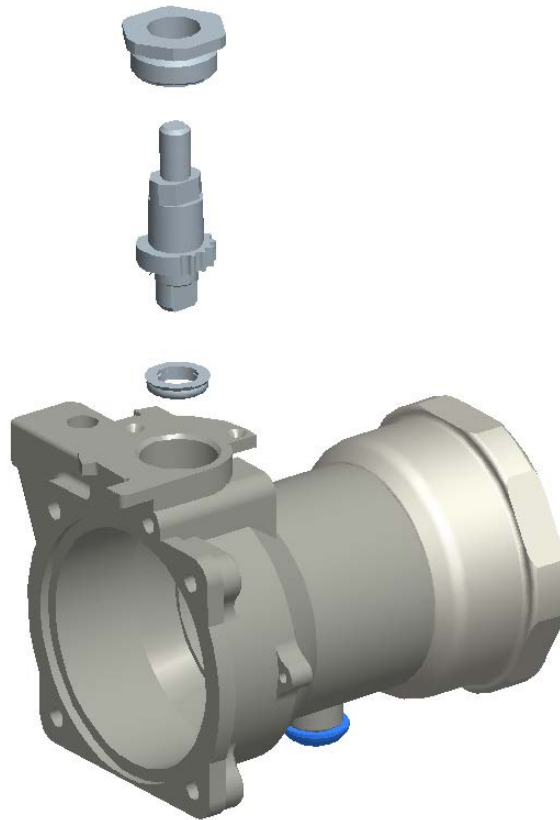

- Unthread stem bearing and remove stem with seal
- Stem seal may hang up in the body. For removal, simply place thumb inside of body cavity underneath of seal spring and press seal out of the body through the stem bore.

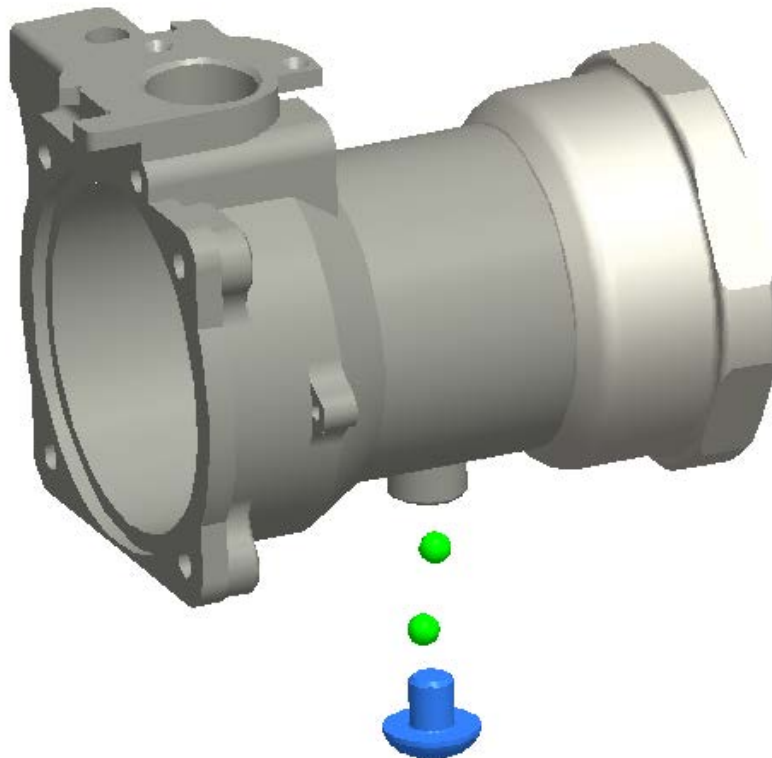

- Remove ball plugs and rotate swivel and body so bearings can fall out (1 and 2 inch unit shown)

- With all bearings removed, separate the swivel end from the body and remove the swivel seal (all units), and sleeve bearing (1 & 2 inch units), and dust seal (3 inch units)

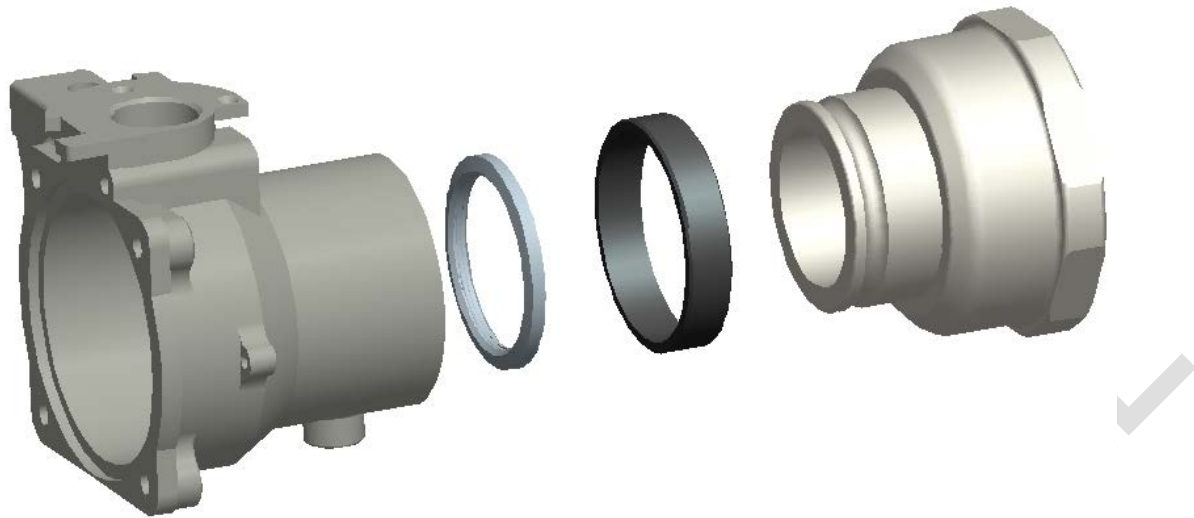

- Note: 2 inch unit shown

CONFIDENTIAL

EPSILON COUPLER PARTS LIST (1" – 3" Coupler Half)

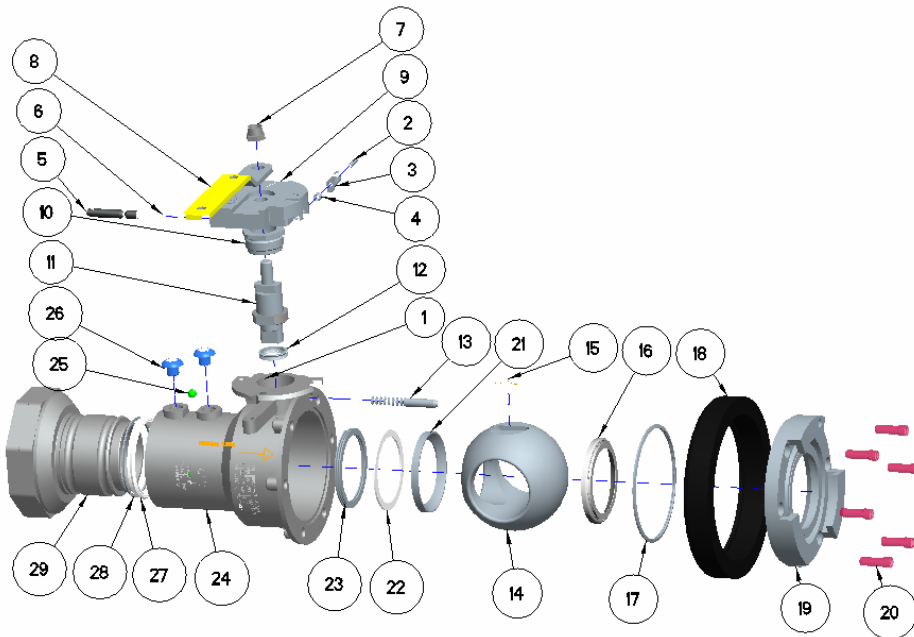
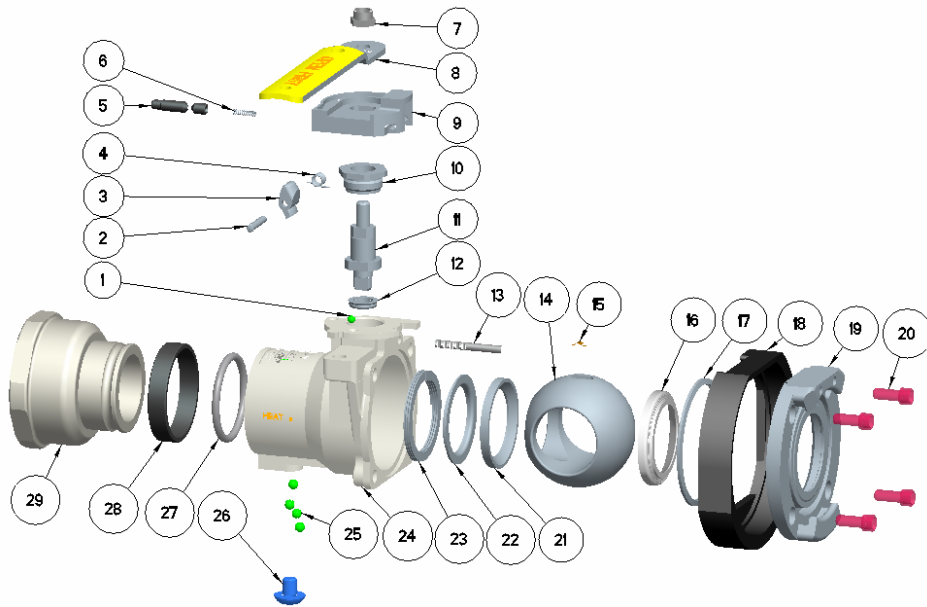

EPSILON COUPLER PARTS LIST

(1" – 3" Coupler Half)

#	Item Description	Part Number 1"	Part Number 2"	Part Number 3"	Qty
1	Ball, Detent	ZE100170-039	ZE100170-039	CTL107A32-25	1
2	Pin, Hub, Latch, incl. in Pos. 9				
3	Latch, Hub incl. in Pos. 9				
4	Spring, Latch, incl. in Pos. 9				
5	Pin, Interlock, incl. in Pos. 9				
6	Spring, Interlock, Hub, incl. Pos.9				
7	Handle Nut, Self Locking	CTL107A16-96	CTL107A32-96	ZE100117-001	1
8	Handle	ZE100201-030	ZE100203-030	ZE100104-003	1
9	Hub Assembly, EPSILON Cplr	ZE00012	ZE00108	ZE00045	1
10	Bearing, Stem	ZE100177-007	ZE100176-007	ZE1000086-007	1
11	Stem, Cplr	ZE100060-002	ZE100313-001	ZE100105-001	1
12	Seal, Stem	ZE100194-040	ZE100012-040	ZE100096-040	1
13	Rack, Interlock, Body	ZE100183-021	CTL107A32-18	ZE100106-021	1
14	Ball, Valve, Convex, T-bore	ZE100280-002	ZE100245-002	ZE100302-001	1
15	Spring, Conductivity	H3195M	H32017M	H31952M	1
16	Seal, Ball	ZE100068-038	ZE100146-038	ZE100092-038	1
17	Seal, Flange	ZE100182-040	ZE100079-040	ZE100098-040	1
18	Bumper, Cplr	CTL107A16-66	ZE100322-021	ZE100122-020	1
19	Standard Flange	CTL107A16-59	ZE100323-007	ZE100262-007	1
20	Screw, SH Cap	ZE100179-018	H20625M	ZE100120-024	4/6
21	Retainer, Valve Ball	ZE100210-038	ZE100209-038	ZE100101-038	1
22	Washer, Wave Spring to Retainer	CTL107A16-54H	ZE107A32-76H	ZE100109-001	1
23	Wave Spring	CTL107A16-38H	ZE100191-004	ZE100084-001	4
24	Body, Cplr	CTL107A16-41	CTL107A32-41	ZE100091-002	1
25	Ball, Swivel	CTL107A32-25	CTL107A32-25	22710-5	16/27/56
26	Screw, Ball Plug	CTL107A32-10	CTL107A32-10	ZE100123-024	1
27	Seal, Swivel	ZE100144-040	ZE100143-040	ZE100095-040	1
28	Bearing, Sleeve	CTL107A16-12	CTL107A32-12		1
28	Dust Seal/3"			ZE100137-015	1
29	Adaptor, Cplr				1

The "yellow" marked parts are included in the Seal Kits

Sign off sheet. Epsilon Coupler Stripping, Decontamination and Packing

Serial Number ⇒					
Step 1					
Step 2					
Step 3					
Step 4					
Step 5					
Step 6					
Step 7					
Step 8					
Step 9					
Step 10					
Notes					

Each step to be initialled and dated by engineer carrying out process.